

2010

marco tempest

technical rider

minimum technical requirements



illusions · technology · media · magic

marco tempest

minimum technical requirements

stage:

Minimum size 25 feet x 25 feet • Black backdrop • Neutral (non-reflective) floor. Height should be sufficient to provide good sight lines to within 6 inches of the floor for all audience members. Easy access should be provided at the back of the stage and on both sides of the stage, so that performer may get on and off the stage to do quick-changes and switch props during performance blackouts.

If performance is to include any audience participation pieces, a safe, wide stair unit must be provided at the front of the stage for performer and audience access.

video playback:

We will create all video assets in digital file based format to integrate into your existing video playback system. If required video elements can be provided on Mini DV or HDcam tape.

For certain performances the use of two or more synchronized VCRs or hard disk video playback device is required. Depending on your setup Marco might be able to supply a pre-configured video playback system. Please consult with us before accepting final bids of your vendor.

live camera:

If Tempest is to perform magic with small objects in a large room a camera operator and a live handheld camera is required. The camera needs to be switchable from live image to the video playback system (vcr). Please check with Tempest if this is a requirement for your event.

audio:

Run from video playback system plus Mixer/ Amp/ Speakers suited to Room.

If Tempest is to speak during this performance, please provide one wireless lavalier microphone and receiver, to be controlled by presenter's sound technicians, with belt pack and clips for attachment to a black t-shirt worn by performer under his jacket (microphone attached to neck of t-shirt).

lights:

A minimum 30 PARCANS / 10 very narrow spot, 20 medium flood plus 2 strong Smoke Machines.
Strongly recommended: Additional 6 Studio Spot or similar intelligent lighting fixtures.

light board:

WholeHog2 or GrandMA or equivalent programmable board. For certain performances a light board which will accept time code from video might be required.

- Gel Colors: Rosco #26 (red)
- Rosco #95 (Blue-green)
- Rosco #68 (Medium Blue)
- Rosco #06 (No Color Straw)

Note: Steep angles on lights as shown below are very important to create the “look and feel” of this performance...and to avoid glares on the video wall.

basic technical set-up (sample light plot):

Please clear actual lighting plot for your event with us prior to completing your final bids.

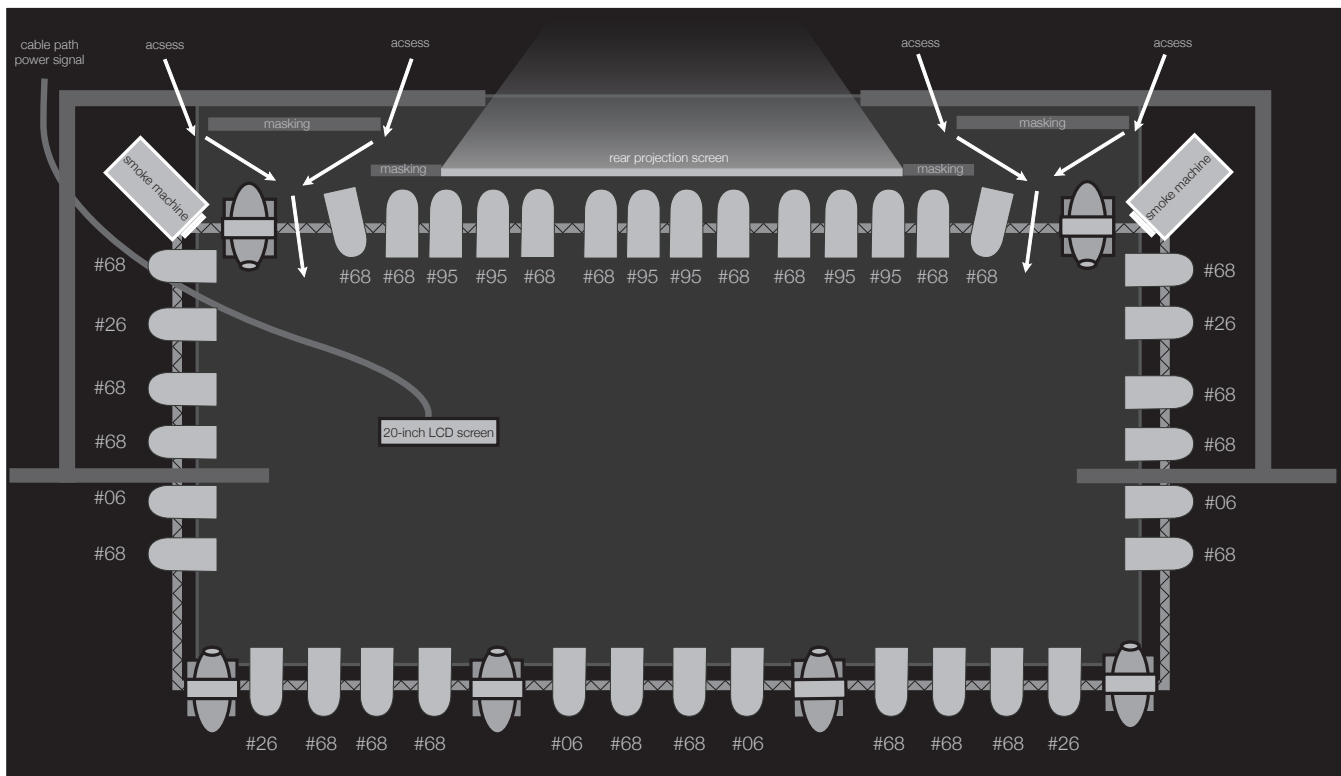

sketches detailing screen / masking arrangements for walkout sequences:

This is the necessary screen set-up for the screen that enables a person to “walk out” as a shadow silhouette. Either of the below shown setups will work... sometimes it is preferable to have the steps so that the screen can be on a higher line of sight. The important thing is for the person to be able to stand in the projector beam, then walk out directly onto the stage at the same level. Other Video Projection System, to be discussed with Tempest prior to Engagement.



Sometimes it is preferable to have the steps so that the screen can be on a higher line of sight. The important thing is for the person to be able to stand in the projector beam, then walk out directly onto the stage at the same level.



Default aspect ratio for the screen walkouts is 4:3 Other Video Projection System to be discussed with Tempest prior to Engagement.

marco tempest

minimum technical requirements

tempest's deliverables:

19-21 inch LCD Monitor (4:3 aspect ratio) on a stand:

In most cases Tempest will supply his own onstage video monitor, **unless otherwise discussed prior to the event.**

video assets:

Tempest supplies all video assets on for Digital Delivery electronically for download or on a HardDrive . If required video elements can be provided on Mini DV or HDcam tape Exact delivery specs to be discussed prior to start of pre-production.

custom props construction:

Tempest will provide customized props (Puzzled, Next Dimension, Mail in Prediction etc.) as discussed prior to the event.

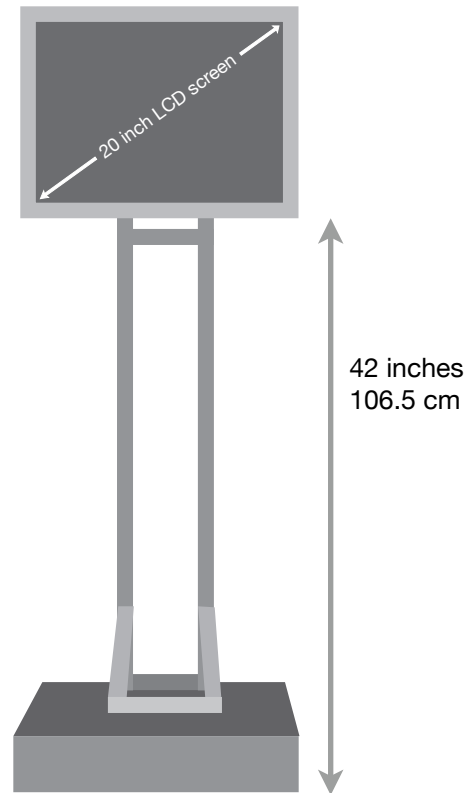

all contact and questions to:

Marco Tempest
Newmagic Communications, Inc.
636 Broadway – Suite 1002
New York, NY 10012
USA

tempest@newmagic.com

NEWMAGIC

ILLUSIONS · TECHNOLOGY · MEDIA · MAGIC

© 2010 newmagic communications, inc. all rights reserved

illusions · technology · media · magic