



CONTRACT RIDER 01.05.2011

The following will be needed for **each** performance day:

1. STAGING:

PURCHASER to provide and pay for the following:

- A stage of at least 20 feet in width, 16 feet in depth and 3 feet in height with steps located on side of stage. **(Front row must be at least 25' from face of easel.)**
- Embossed Vinyl sheeting (matted black "Velon") to cover entire stage and surrounding areas (walls, low ceilings, etc.)
- One (1) 12' by 16' (minimum) piece of thick indoor black carpet. Please be advised that this carpet will get paint on it.
- Eighteen (18) terry cloth hand towels and three(3) full-size bath towels per show (for use on stage). Towels should be solid white.
- Five- (5) five-gallon **black** buckets, three-quarters filled with room-temperature water. Buckets should be new, plastic style with no labels.
- One (1) 2" by 60-yd rolls of black gaffer's tape. *Black duct tape will not be acceptable.*
- Four (4) sets heavy weight stretcher bars, with cross braces 68x54". Minimum of two (2) hours of set-up and rehearsal time.
- Minimum of two (2) experienced stagehands to be available during load-in, set-up and rehearsal, breakdown and load-out. These hands should be the same individuals for the entire event.
- Paint as per enclosed rider.
- Flats for use as easel, as per enclosed rider. These must be painted flat black, and weighted with sandbags or fastened to the floor.

Note: If stage is outdoors, special arrangements must be made to accommodate inclement weather, cold, heat, etc.

2. SOUND AND LIGHTS:

PURCHASER TO PROVIDE AND PAY FOR THE FOLLOWING:

A) LIGHTING REQUIREMENTS:

- Minimum of six (6) Source 4/ Parnel par fixtures or comparable with dimmer. These will be arranged two (2) per side of stage (artwork wash), on Ultimate Support Stands or equivalent. Two (2) Source 4/ Parnel fixtures (front wash). Instruments are to be set with diffusion gels Rosco 114 (no color) and frames should be provided. Please see attached lighting and stage plot. **Further arrangements for lighting can be made upon conversation with Brian's tour manager at the office number listed below.**
- One (1) experienced and knowledgeable lighting electrician or grip to set-up and operate lighting for entire show.
- **Lighting is to be set up, operational and ready for focus prior to load-in.**

B) SOUND REQUIREMENTS:

- One (1) Class A sound system adequate for the size of the venue, capable of stereo, with at least two- (2) microphone inputs and two (2) pairs of line-level stereo inputs for CD players. Sound system must have two (2) monitor output. *Bose, Soundcraft, Yamaha, Apogee, EAW or Meyer brands are preferred.*
- One (1) straight microphone stand with Shure-style microphone clip and cable for SM-58. Microphone will be provided by the artist.

- Two (2) full-range monitors located on downstage corners for artist playback.
- One (1) SM-58 microphone with straight stand for use as back up, cabled, tested and located off-stage with enough cable to be taken on-stage.
- Two (2) CD players. Capable of playing CD-R discs. (One used as back- up)
- One (1) experienced and knowledgeable sound engineer to set-up and operate sound system.
- **Sound system is to be set up and operational prior to Artist load-in.**

3. PROJECTION AND VIDEO REQUIREMENTS:

- If show will be projected or video recorded, special arrangements should be made with Brian's Tour Manager at the office number listed below. Screens and all cameras must be available during rehearsal.
- Copy of all footage to be provided to the artist no later than two weeks following the performance.
- **Projection Screens and all Cameras to be set up and operational prior to Artist load in.**

4. DRESSING ROOMS:

PURCHASER to provide one (1) comfortable, private dressing room, located within reasonable distance from stage, for the exclusive use of Brian Olsen, equipped with the following:

- Two- (2) new plastic 5-gallon buckets three-quarters filled with room-temperature water. These are in addition to the stage buckets.
- Two- (2) chairs and small table

5. CATERING:

PURCHASER to provide and pay for the following:

The following to be on ice, in the dressing room one hour before show time:

- Six (6) 12oz bottles of non-carbonated spring water (Evian, etc.)
- One 6-pack of regular Coke

6. HOTEL ACCOMMODATIONS

PURCHASER to provide and pay for two (2) standard rooms with king-size beds at a *First-Class, minimum Four Star hotel* (as per contract).

7. TRANSPORTATION

PURCHASER to provide and pay for two (2) airline tickets to and from event.

PURCHASER to provide and pay for private ground transportation (as per contract)

If there are any questions regarding the rider requirements, meals, hotels, transportation, flight information or directions, please contact Brian's Tour Manager at the office number listed below.

Brian Olsen Tour Manager

Office: 720.570.2303

AGREED TO AND ACCEPTED:

Client Date

BRIAN OLSEN Date



ART IN ACTION PAINT LIST

The following is the paint list required for Brian's performance. The cans of paint must be in 1-quart cans of Sherwin Williams Interior Matte Duration interior as noted below.

<u>COLOR</u>	<u>PAINT NUMBER</u>	<u>FLAT</u>	<u>QUANTITY</u>
1. Black Tie	#1007	Flat	1
2. Princely Purple	#1833	Flat	1
3. Isle of Capri	#1783	Flat	1
4. Tide Pool	#1754	Flat	1
5. Extra White	#7006	Flat	2
6. Deco Coral	#1615	Flat	2
7. Valencia	#1616	Flat	1
8. Theater Red	#1602	Flat	1
9. Memphis Yellow	#1686	Flat	1
10. Liana (Lime Green)	#1727	Flat	1
11. Pink Hibiscus	#1594	Flat	1

2 (two) black plastic wallpaper troughs 33" long

15 (fifteen) paint-stirring sticks will be needed. These are free at the paint store.

* Have Sherwin Williams Mark top of cans with a paint spot.

* Important: Brian will need a complete paint set up for each day of performance. (If the total paintings per day exceed four per day please contact for Brian's Tour Manager for the correct amount to order.)

2075 South University Blvd
#153
Denver, Colorado 80210

720.570.2303 **phone**
720.221.0790 **fax**
www.brianolsenart.com **web**



BRIAN OLSEN
ART IN ACTION®

BRIAN OLSEN EASEL CONSTRUCTION

1/4" holes drilled 17" from center edge of sheet and 7" from top

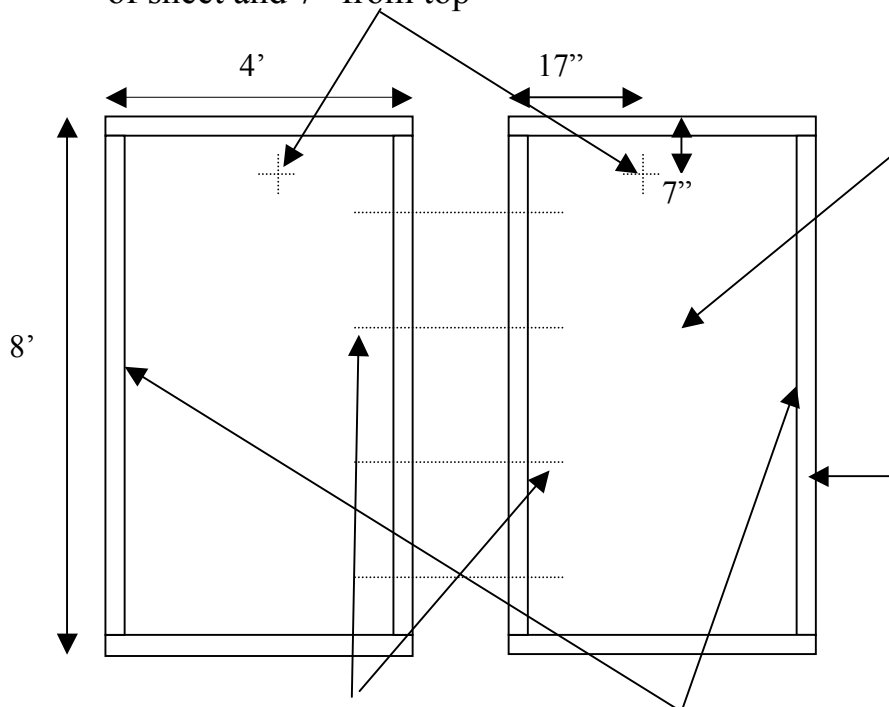

4' x 8' sheets of 1/2" plywood with face side of B-grade or better. Face side must be painted flat black

Framing on back side of plywood consisting of 2" x 4" lumber. Narrow edge of framing to be attached to plywood with drywall screws

4' x 8' flats are connected together with 1/2" x 5" bolts with washers.

Braces attach along the inside of this edge

EASEL BRACES.

Constructed of 2" x 4" lumber. Attached to easel flats by 1/2 inch bolts through 4" "ears" left extending horizontally toward flat. Two braces must be built. Note that bottom horizontal member must be high enough from floor to clear frame on easel, and must extend at least 4" past vertical piece to fasten properly to flat frame. Easel is to sit vertically on stage.

SIDE VIEW

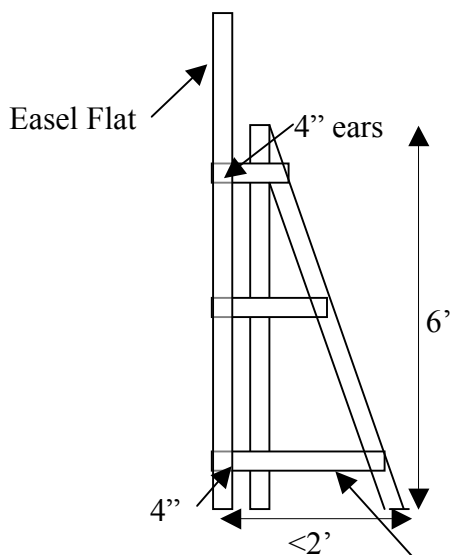

NOT TO SCALE

Sandbags or stage weights must be used at this point to counterweight the flat or attach it to the floor

2075 South University Blvd
#153
Denver, Colorado 80210

720.570.2303 **phone**
720.221.0790 **fax**
www.brianolsenart.com **web**